

INSTALLATION INSTRUCTIONS

2017 Double Canopy / Full Enclosure

Tracker Marine Regency 220 LE3

PARTS LIST

DOUBLE CANOPY:

1 Bow Canopy
 1 Bow Canopy Boot
 1 Aft Canopy with Front Zipper
 1 Hardware Package
 1 Bow Frame

FULL ENCLOSURE:

1 Aft Canopy with Zippers
 1 Hardware Package
 1 Aft Curtain
 1 Bow Canopy with Zippers
 2 Aft Side Curtains (1 Port, 1 Starboard)
 2 Bow Side Curtains (1 Port, 1 Starboard)
 1 Bow Curtain
 1 Bow Frame
 1 Bow Boot

TOOLS REQUIRED

Measuring Tape
 Center Punch
 Drill
 21/64" Drill Bit
 Pencil
 Phillips Screwdriver
 Adjustable Wrench



WARNING

INDICATES POTENTIAL HAZARD
 THAT COULD RESULT IN DEATH
 OR INJURY



CAUTION

INDICATES POTENTIAL
 HAZARD THAT COULD
 RESULT IN BOAT DAMAGE



NOTE

INDICATES SPECIAL INFORMATION
 TO MAKE MAINTENANCE EASIER
 OR INSTRUCTIONS CLEARER



NOTE:

This enclosure is designed to fit the 2016-17 Tracker Marine Regency 230 LE3 Pontoon Boat that has the aft canopy brackets, deck buttons, and eye straps in the following locations:

Main Power Arm Aft Bracket: 73 3/4"

Measurements should be taken from the end of the back of fence for Aft Canopy Brackets and as shown below for bow canopy brackets and buttons in the following locations:

Aft Main to Bow Main: 123"

Bow Main to Hold-down Arm: 26"

All measurements are taken to the center of the brackets unless indicated otherwise.

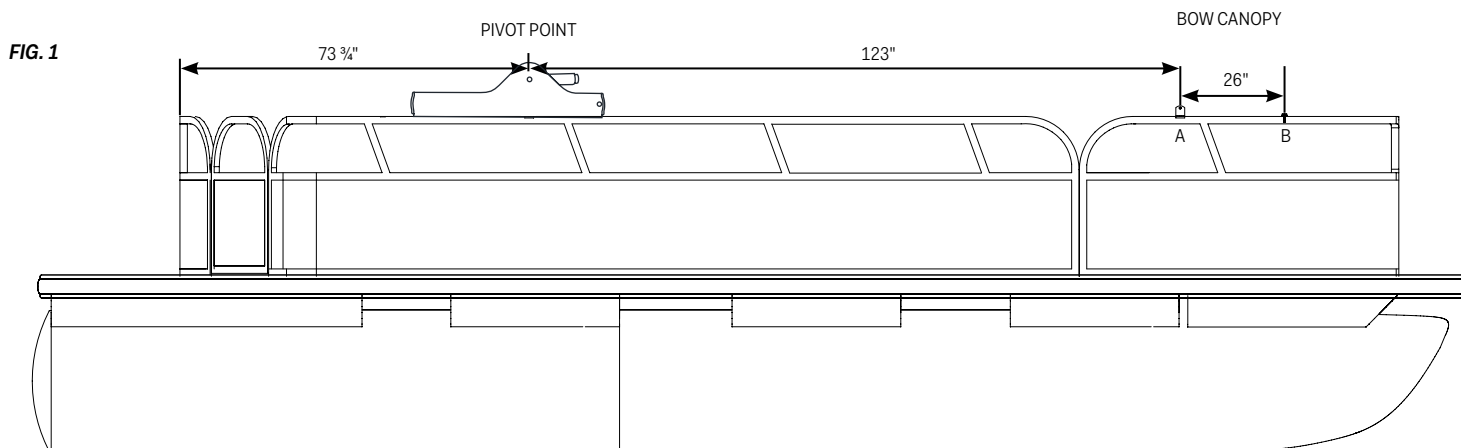

NOTE:

Your pontoon has been pre-assembled with an aft canopy and aft canopy frame from Tracker Marine. The aft canopy that is supplied with the pontoon is not designed to be used with an enclosure. You must remove the standard aft canopy and replace it with the aft canopy that is supplied with the purchase of your enclosure. Once the new canopy is installed, raise the entire unit to the "up" position. Make sure the aft canopy is centered on the frame between the port and starboard sides. This step is very critical; it will determine the final appearance of your completed enclosure.

BUTTON MOUNTING DETAIL

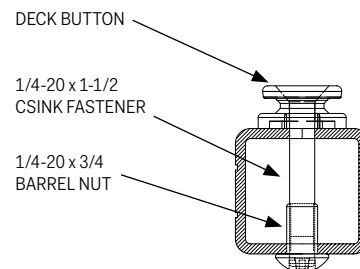

BRACKET LOCATIONS & ASSEMBLY (FIGURES 1 & 2)

STEP 1

Bracket location (A). Measure and place a mark on the top rail 123" forward from center of power arm pivot point on aft main bracket.
 Bracket location (B). Measure and place a mark on the top rail 26" forward from (A).

STEP 2

Center the brackets at each mark as shown in Figure 2. Transfer the centers of each hole at the bottom of the bracket on to the rail using a center punch.

STEP 3

Using 5/16" drill bit, drill holes completely through the top rail.

STEP 4

Replace the brackets. Insert a short shoulder bolt from the top through the bracket and the rail. Place a barrel nut on and tighten (Figure 2).

STEP 5

Follow the same procedure for the other side.

FIG. 2

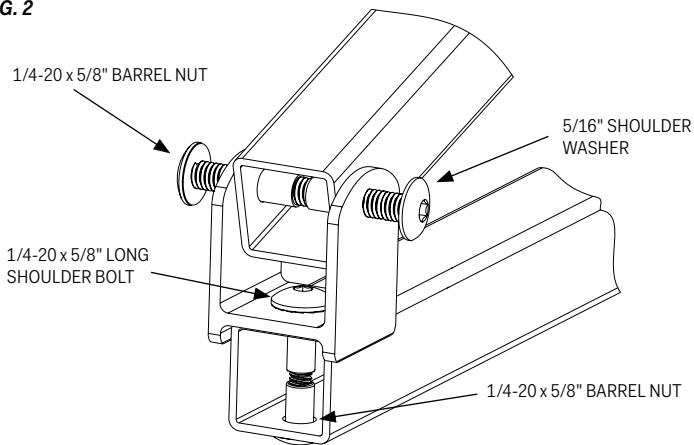

CAUTION

TO PREVENT DAMAGE TO THE TOP RAIL, IT IS RECOMMENDED TO DRILL A PILOT HOLE FIRST.

BOW CANOPY & BOW CANOPY FRAME ASSEMBLY (FIGURE 3)

STEP 1

With two people, lift the bow frame onto the boat and insert the main bow tube into the previously installed bow brackets. Using barrel nuts and shoulder bolts (inserting shoulder washers, see Figure 2), secure the frame to the rail (Figure 2).

STEP 2

Once the frame is secure, raise the assembly up and latch the hold-down arms to the deck buttons.

STEP 3

Lay the secondary and auxillary bows toward the aft of the boat. Zip the front pocket of the bow canopy to the main bow. Release the hold-down arms and zip the bow canopy to the aft canopy. Push up the auxillary bow and zip inside pocket. Push the secondary bow up and zip inside pocket.

STEP 4

Center the bow canopy before re-securing the hold-down arm to the buttons.

FIG. 3

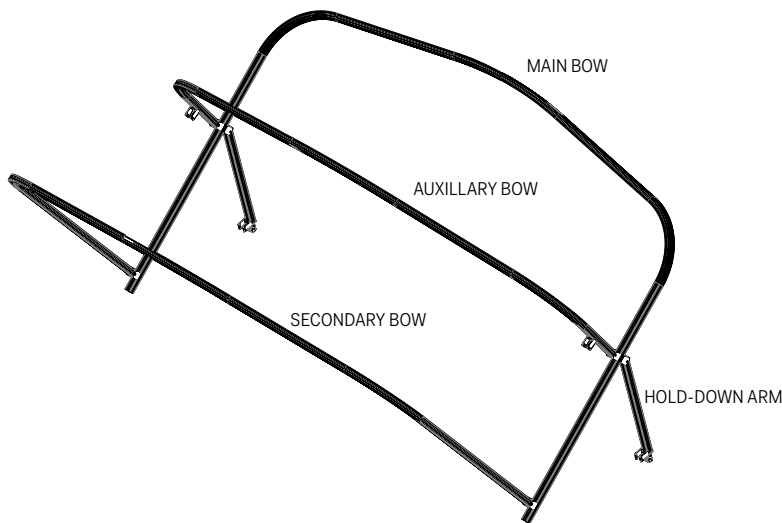

NOTE: NOT ALL BOW FRAMES HAVE AN AUXILLARY BOW

CURTAINS (FIGURE 4)

STEP 1

Each curtain has a tag sewn in the upper left-hand corner of the flap. This will identify each curtain and give its location on the pontoon.

STEP 2

The curtain flaps will face the inside of the pontoon.

STEP 3

Start with the Bow and Aft curtains. Zip approximately 6" of the Aft curtain to the top. Insert the RailLok HC clips in the rail and slide them down the rail as you insert them. Finish zipping the curtain to the top. Repeat this process for the Bow curtain and side curtains.

STEP 4

Finally zip all curtains together.

STEP 5

To remove the curtains, unzip all of the curtains, then unzip each curtain from the top. That will release the tension to remove the RailLok HC clips from the rail.

NOTE: This is a floating system and can be shifted along the rail for better fit if needed.

FIG. 4

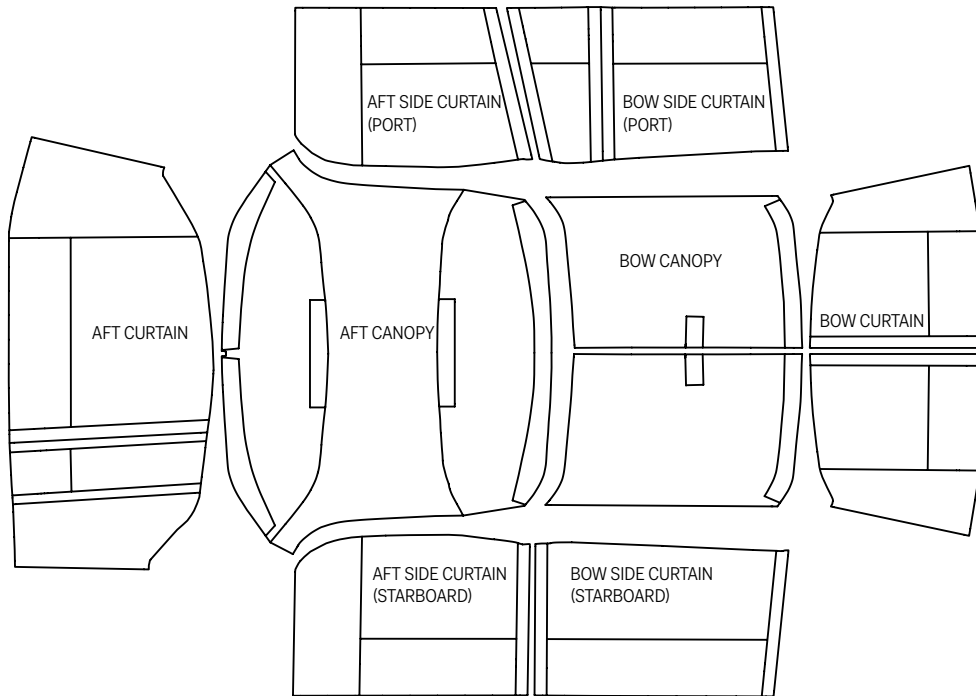
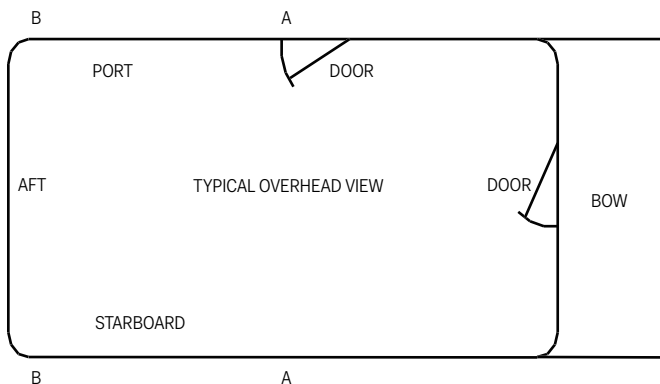

FIG. 5



CARE

WARNING
 DO NOT TRAILER BOAT WITH ANY CANOPY TOP UP (IN RADAR ARCH POSITION) OR WITH THE ENCLOSURE ASSEMBLED!